

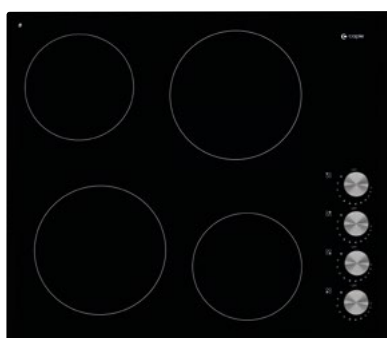

CAPLE CARE

FREE 2 YEAR
PARTS & LABOUR
GUARANTEE

ELECTRIC CERAMIC HOBS



DIMENSIONS

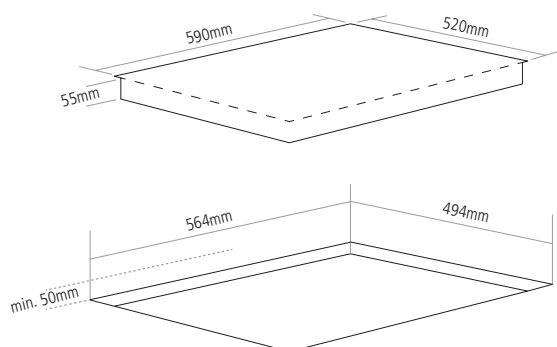

PRODUCT CODE

C809C

DIMENSIONS

w:590mm

FINISH AVAILABLE

Black glass

FEATURES

- Frameless
- Indicator lights for each zone
- Residual heat indicators

COOKING OUTPUT

- 4** Ceramic Plates
- 2 Dia. 200mm – 1.8kW
- 2 Dia. 165mm – 1.2kW

INSTALLATION

- Rated load 6.6kW
- Fuse rating 25A