

N 30, Built-in oven, 60 x 60 cm, Stainless steel
 BIGCCOANOB



COOKING PASSION SINCE 1877



A



- ✓ CircoTherm® – Smart hot-air solution that lets you bake on up to three levels at once.
- ✓ LED-Display - simple, straightforward for clear reading

Features

Technical Data

Color / Material Front : Stainless steel
 Construction type : Built-in
 Integrated Cleaning system : No
 Required niche size for installation (HxWxD) : 585-595 x 560-568 x 550 mm
 Dimensions : 595 x 594 x 548 mm
 Dimensions of the packed product (HxWxD) : 675 x 690 x 660 mm
 Control Panel Material : Stainless steel
 Door Material : Glass
 Net weight : 31.639 kg
 Usable volume of cavity : 71 l
 Cooking method : Conventional heat, Full width grill, Hot Air, Hotair gentle, Hot air grilling
 First cavity material : Other
 Oven control : mechanical
 Number of interior lights : 1
 Approval certificates : CE, VDE
 Length of electrical supply cord : 120 cm
 EAN code : 4242004234036
 Number of cavities (2010/30/EC) : 1
 Energy efficiency rating : A
 Energy consumption per cycle conventional (2010/30/EC) : 0.97 kWh/cycle
 Energy consumption per cycle forced air convection (2010/30/EC) : 0.81 kWh/cycle
 Energy efficiency index (2010/30/EC) : 95.3 %
 Connection rating : 2990 W
 Fuse protection : 13 A
 Voltage : 220-240 V
 Frequency : 50; 60 Hz
 Plug type : no plug

Optional accessories

- Z11AB15A0 Baking tray, non-stick ceramic coated
- Z11CB10E0 Baking tray, grey enamelled
- Z11CR10X0 Baking and roasting grid (standard)
- Z11TF36X0 3 level telescopic rails, full ext
- Z11TI15X0 Cliprails
- Z12CQ10A0 Grill tray, anthracite enamelled
- Z1913X0 Baking Stone



N 30, Built-in oven, 60 x 60 cm, Stainless steel
B1GCCOANOB



COOKING PASSION SINCE 1877

Features

Design

- LED Display (Red)
- Cavity inner surface: enamel grey

Features

- Control panel lock
- Interior halogen light

Cleaning

Programmes/functions

- Cooling fan

Accessories

- 1 x combination grid, 1 x universal pan

Performance/technical information

- Energy efficiency rating (acc. EU Nr. 65/2014): A
Energy consumption per cycle in conventional mode: 0.97 kWh
Energy consumption per cycle in fan-forced convection mode:
0.81 kWh
Number of cavities: Main cavity
Heat source: electrical
Cavity volume: 71 litre
- Total connected load electric: 2.99 KW
- 120 cm Cable length
- Nominal voltage: 220 - 240 V
- Appliance dimension (hxwxh): 595 mm x 594 mm x 548 mm
- Niche dimension (hxwxh): 585 mm - 595 mm x 560 mm - 568 mm
x 550 mm
- Please refer to the dimensions provided in the installation manual

N 30, Built-in oven, 60 x 60 cm, Stainless steel
 BIGCCOANOB



COOKING PASSION SINCE 1877

Dimensioned drawings

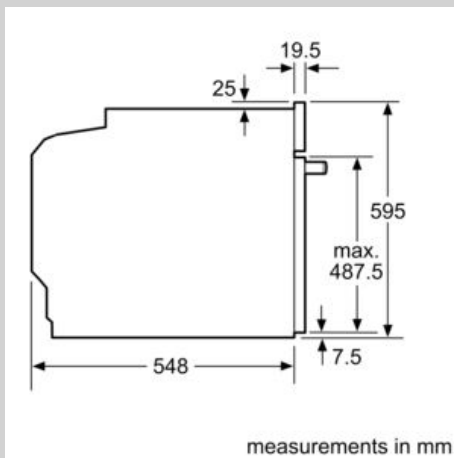
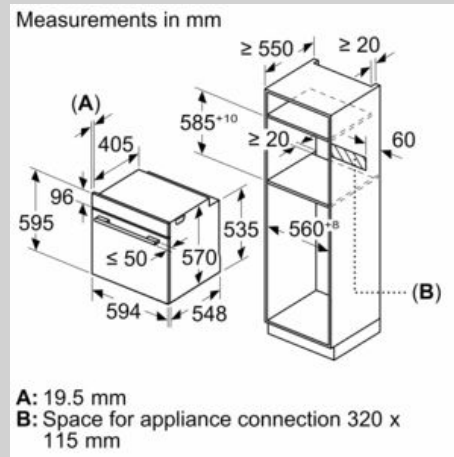
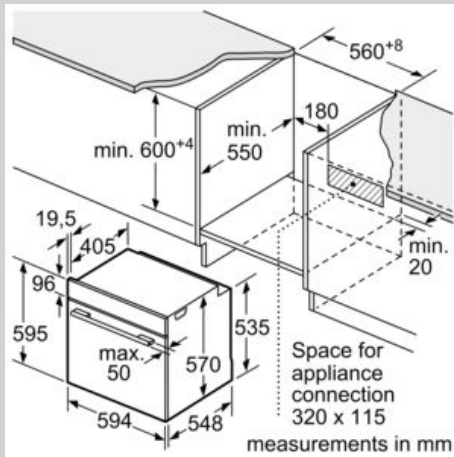

Installation with a hob.

